

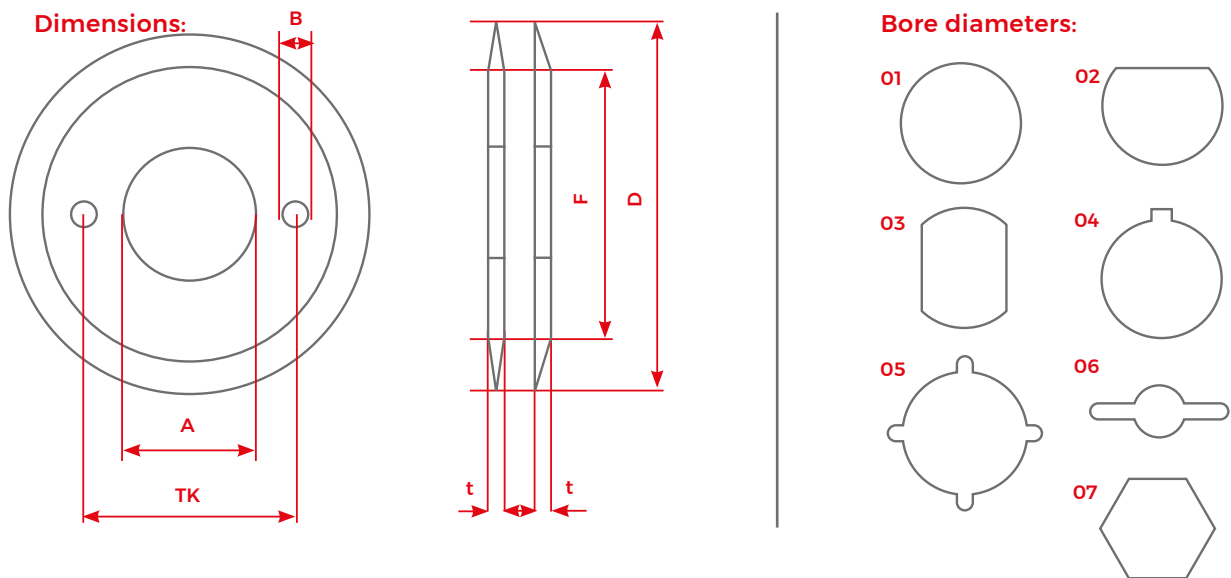

Circular knives

To help us process your circular knife enquiry, please complete the following table and send the form to office@hoppeschliff.de.



| | | | | | |
|----------------------------------|----------------|------------------------------------|--|---|-------------------------------------|
| Please complete: | Initial | Size in mm | | | |
| Outer diameter | D | | | | |
| Blade thickness | t | | | | |
| | | Size in mm | Shape | | |
| Bore diameter | A | | | | |
| | | One-sided | Double-sided | | |
| Bevel length (diameter) | F | | | | |
| | | Straight | Teeth | Hollows | Slots |
| Bevel profile (please cross box) | | | | | |
| | | Size in mm | Number | | |
| Bores/side holes | B | | | | |
| Pitch circle | TK | | | | |
| | | Tool steel (DIN 1.2379) | High-speed steel (DIN 1.3343) | Stainless/acid-resistant steel (DIN 1.4034/1.4112) | Tungsten carbide (Widia) |
| Material (please cross box) | | | | | |
| Quantity/batch | | | | | |



Circular knives / cutting edge geometries

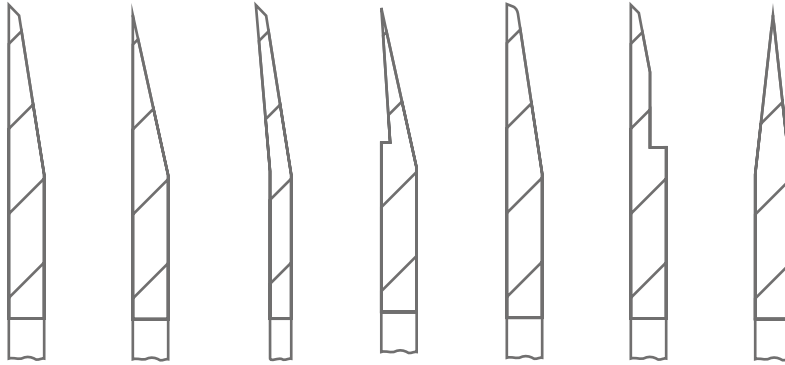

01 02 03 04 05 06 07

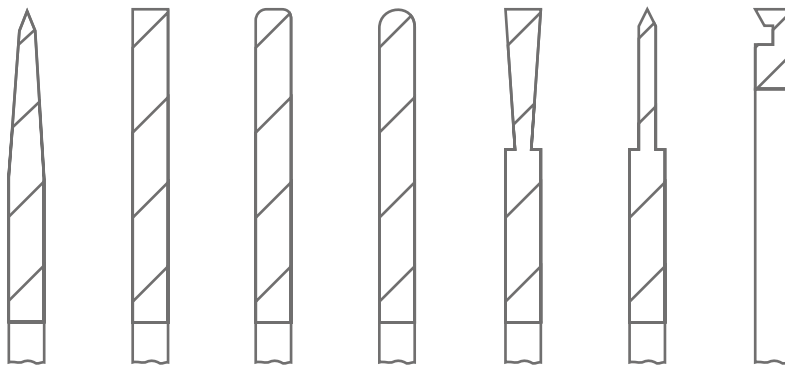

08 09 10 11 12 13 14

- 01 Single-sided double bevel
- 02 Single-sided single bevel
- 03 Slim bevel, hollow ground (disc knife)
- 04 Single-sided single bevel, undercut
- 05 Single-sided single bevel, pre-bevel rounded
- 06 Single-sided double bevel, flat thinned out
- 07 Double-sided single bevel
- 08 Double-sided double bevel
- 09 Grind blunt 90°
- 10 Grind blunt 90°, double-sided rounded, quarter radius
- 11 Grind rounded, complete radius
- 12 Bevel double-sided flat hollow ground
- 13 Double-sided single bevel with collar (crush cut)
- 14 Bevel one-sided with undercut (cup wheel)

| | |
|-------------------------|---------------|
| Please complete: | Number |
| Cutting edge geometries | |

Your contact details:

Company _____ Contact person _____

Phone _____ E-Mail _____

Address _____